

# AREDN® Network Beginner's Guide - for the Absolute Newbie

## What it's all about

By loading the AREDN®<sup>1</sup> firmware in a outdoor wireless access point, you can join a ham radio network. It's like the Internet but runs on ham radio frequencies, mostly in the 5.8 GHz bands.

By joining this network you can find and use all sorts of applications (known as "services"). Anything running on a server, like weather stations, web sites showing site conditions and camera views, email servers, etc can be provided as a service. There are also services that don't rely on a browser: video streams, chat servers, VOIP PBXes, etc. The network can also be used to host Winlink post offices, Dstar and DMR repeaters, and Allstar devices.

Pretty much any kind of service you can put on the Internet you can put on the AREDN® network, subject to the restrictions of the ham radio regulations (FCC Part 97).

## Getting started

The network is growing steadily, but the number of accessible nodes in your area can range from plentiful to none within hundreds of miles.

## RF access to the network

How do you find out where the nearest network node is? There are several ways:

- Check the maps at <https://www.arednmesh.org/>, both the legacy map and the newer World Map.

---

<sup>1</sup> AREDN® is a registered trademark of the Amateur Radio Emergency Data Network, Inc.

## **AREDN® Network Beginner's Guide - for the Absolute Newbie**

- Register an account on [arednmesh.org](http://arednmesh.org) and see if there's a Regional Forum for your area. Ask in there for local information.
  - If you don't find a regional forum for your area, get it started by asking the webmaster, Randy WU2S to create one for you. Search for his callsign using the search function, and by finding it you'll be able to drop him a note. Once it's created, create a post mentioning you'd like to get started and asking if there's any activity near you.
  
- Ask around your local ham club or on a local net.

If you determine there is a local node, how do you find out if you can reach it?

For these devices, line of sight is REALLY line of sight; they don't do trees well at all. There are a number of on-line LOS calculators, ranging from simple to use to really complex. A simple one is at <https://heywhatsthat.com>. By entering your location, expected elevation of your node, and naming it, the site will generate a coverage plot for you. You can do this for your QTH and/or any existing local nodes.

Note - these plots assume omnidirectional coverage, and most all network nodes on hilltops use directional sector antennas. But the plots will let you know if there's a possibility of connecting via RF to that node.

# AREDN® Network Beginner's Guide - for the Absolute Newbie

## Alternate access to the network

If after doing your research you find that you don't have any RF path to the network, don't despair; there is an alternative. The nodes have the capability of 'tunneling' over the Internet to another node. While this isn't a 'real' radio connection it will let you get on the network until such time as the network has grown into your area.

In order to establish a tunnel, you'll need the Mikrotik hAP ac3 router which, when running AREDN® firmware will provide your node access to both the AREDN® network and the Internet (plus a number of other features that are really useful when running a ham network in your shack).

## Recommended equipment

**Note:** these recommendations are for a base station; recommendations for network nodes on hilltops are likely to be different and beyond the scope of this introductory article.

In order to ensure good performance you need a strong link into the network. Like most other ham radio activities more gain is better than less. And even if you have two nodes within range, the node's routing software will always pick the strongest one as your path into the network. So omni antennas are discouraged and dish antennas greatly preferred.

All of the equipment using directional antennas that is supported by AREDN® use electronics integrated into the dish feedpoint: two transceivers, two modems, and an embedded computer with RAM, ROM and a network interface. They are all POE-enabled (Power Over Ethernet). This avoids having to run both a network

## **AREDN® Network Beginner's Guide - for the Absolute Newbie**

cable and a power cable up the mast to the node. A web interface is used to control and configure the device.

AREDN® now supports over ~~80~~ ~~100~~ 120 devices (including those added in the nightly builds) so there are many options when choosing what to buy.

The Mikrotik dishes may be slightly less durable than the equivalent Ubiquiti so if you live where there's severe icing that may be an issue. But the Mikrotik dishes are lighter, making them more suitable for portable work (e.g., go boxes). Both brands work well.

# AREDN® Network Beginner's Guide - for the Absolute Newbie

## Short Haul Nodes



Mikrotik SXTsqG-5acD  
16 dBi gain - ~10-12 miles

Mast clamp optional - but  
recommended



Nanostation 5 ac  
16 dBi gain - ~10-12 miles

# AREDN® Network Beginner's Guide - for the Absolute Newbie

## Longer Haul Nodes



Ubiquiti LiteBeam ac gen2  
23 dBi gain (recommended!)



Ubiquiti PowerBeam AC 500  
25 dBi gain



Mikrotik RBLHGG-5acD 24.5 dBi gain

Mikrotik RBLHGG-5acD-XL 27 dBi gain

## AREDN® Network Beginner's Guide - for the Absolute Newbie



LDF 5 ac - Light Data Feed. This is a unique device. By itself, it only has 9 dBi gain. But it's made to be mounted in a standard 40 mm dish LNA mount.

That means any dish - including a repurposed DishTV or DirectTV dish. Those typically will provide overall gain of 22-25 dBi.

These are perfect if you live in an area with a restrictive HOA or CC&R. Your neighbors will never notice the dish isn't pointed up at some synchronous satellite!



The universal mount is available for about seven dollars from Amazon (<https://amzn.to/34QCvSj>).

# AREDN® Network Beginner's Guide - for the Absolute Newbie

## In the shack

The Mikrotik hAP ac3 (RBD53iG-5HacD2HnD) is a five-port router. It provides a seamless method for integrating the ham radio network into your ham shack network.



When running AREDN® firmware, it provides:

- One port to connect to your outside node (a “DtD” - Device to Device port). POE power for the node can be enabled on this port.
- One port to connect to your home router, for Internet access [necessary if you need to tunnel your node to another node for network access].
- Three ports that can be used to connect your shack PC to both the Internet and the mesh network (eliminating the need for two computers in the shack, one on each network), with two spare ports for things like cameras, VOIP phones or Raspberry Pis.

Over and above those features, it provide two internal radios, a 2.4 and a 5.8 GHz. Either radio can be configured as a mesh node OR as a wireless access point. Having a wireless Part 15 access point on your shack's ham network is very handy - you can link your laptop or smartphone to it wirelessly and have access to both the Internet and the ham net.

And either of the internal radios can be configured as a wireless access client. This is handy if you're traveling and wind up in a hotel that charges for Internet access on a per-device basis.



# AREDN® Network Beginner's Guide - for the Absolute Newbie

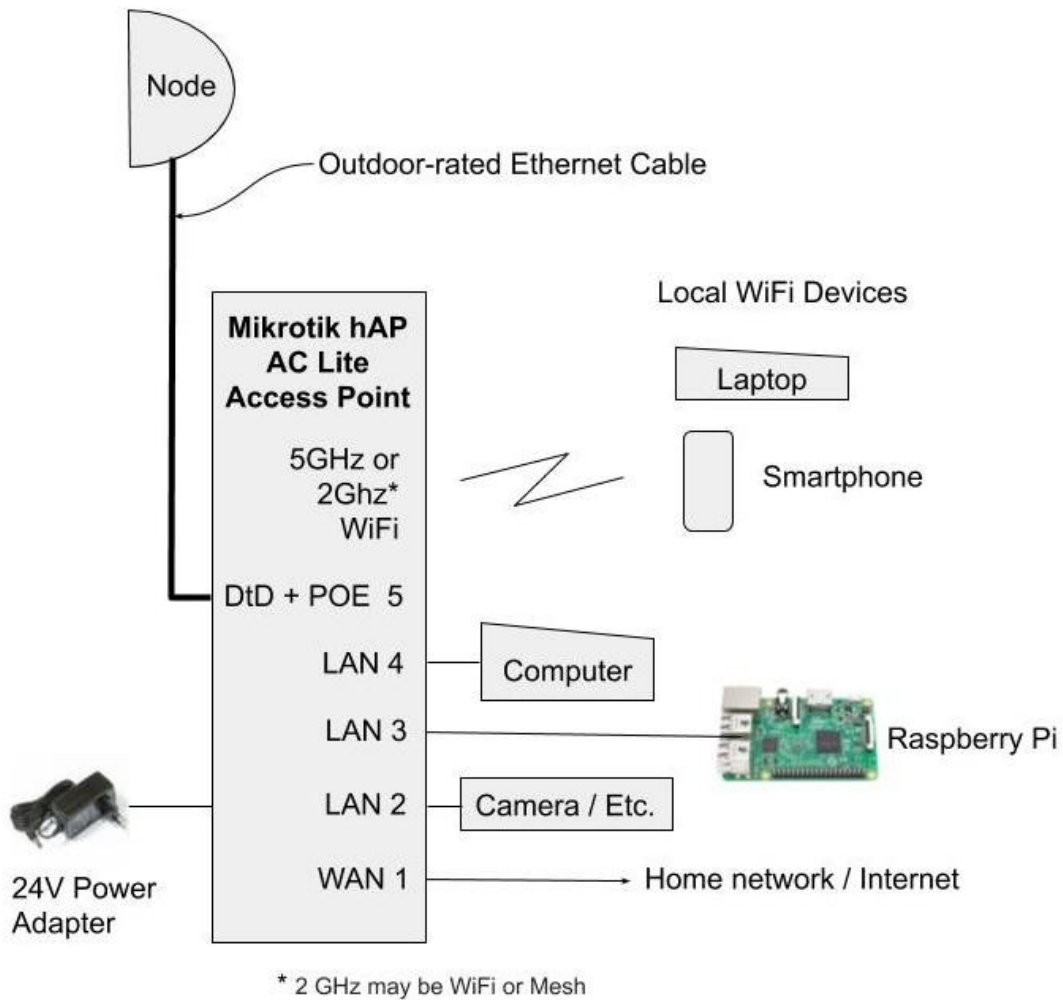

**Example integration of a Mikrotik hAP into the station network – recommended!**

## Configuring your node

After you have your equipment in hand, you have to install the AREDN® software, configure its settings and put it up in the air.

Installation and configuration of the AREDN® firmware is well covered in the [AREDN on-line documents](http://arednmesh.org) at [arednmesh.org](http://arednmesh.org) (See [Installing AREDN Firmware](#) and [Basic Radio Setup](#)).

# AREDN® Network Beginner's Guide - for the Absolute Newbie

## Aiming

Note that the higher the gain, the narrower the beamwidth and the trickier it is to aim these dishes accurately. Fortunately, some aiming tools have recently been added to the AREDN® firmware that help greatly in setting up the dish in the correct direction (and elevation; their vertical beamwidth is as narrow as their horizontal beamwidth).

In the Charts area, you'll see a real-time SNR chart. To the left of it is the audible tuner. Select the device you're aiming at from the drop-down labeled "Selected Device".

Note - when aiming, slew the dish slowly, as the indicators (visual and audible) are slow to update.

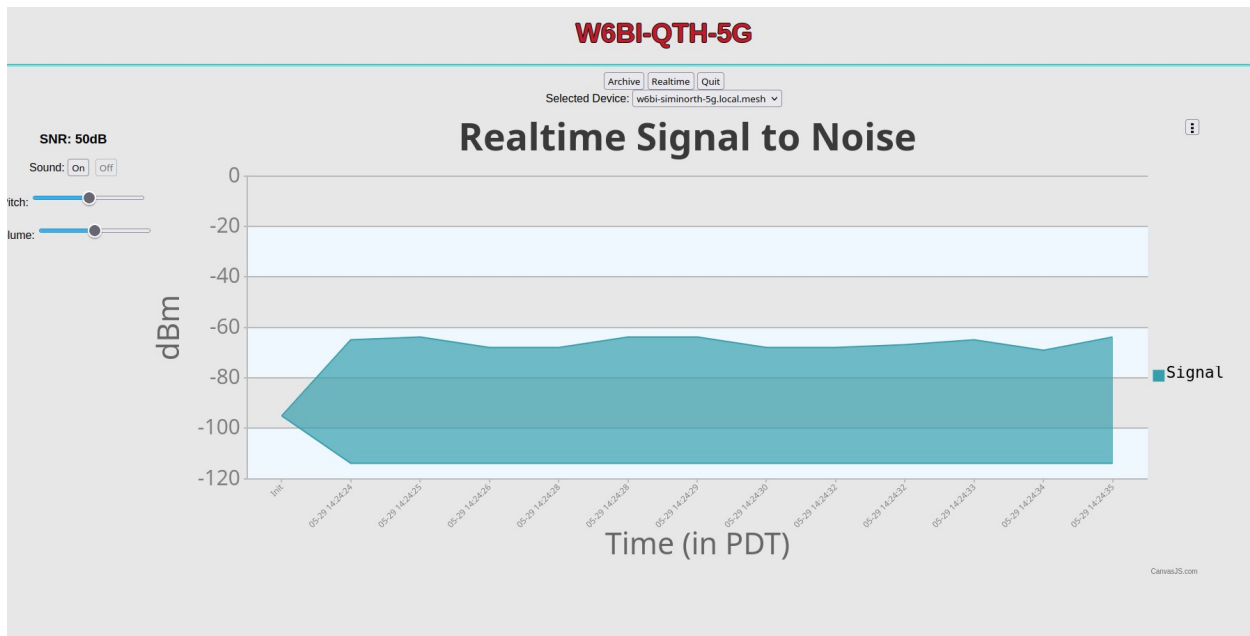

# AREDN® Network Beginner's Guide - for the Absolute Newbie

## Coverage tools

- heywhatsthat.com - easy to use
- <https://ispdesign.ui.com/#> - easy to moderate
- <https://www.scadacore.com/tools/rf-path/rf-line-of-sight/> - easy
- Radio Mobile - <http://www.ve2dbe.com/english1.html> - complex

## Fresnel Zone tool

- [radiofresnel.com](http://radiofresnel.com)

The Fresnel zone is how much your radio link 'spreads' between source and destination. If anything impinges into the Fresnel zone, your signal could be degraded. This tool calculates that zone for you.

**Important note #1** - A number of older devices have been flagged as candidates for sunseting in the future. Avoid them when possible. The AREDN® team has flagged those devices in their Supported Devices Matrix:

<https://www.arednmesh.org/content/supported-devices-0>

Purchasing legacy 802.11n devices, although many of them are still supported by AREDN, is no longer recommended. And they are becoming increasingly hard to find as vendors wind down their manufacturing of them. With the support for 802.11ac devices recently added, consider them for your primary purchase - being a newer generation of hardware they have faster CPUs, more RAM and Gigabit Ethernet ports.

## **AREDN® Network Beginner's Guide - for the Absolute Newbie**

**Important note #2** - Do not stand in front of the radio for extended periods of time when it's powered on. NEVER look into the focus of the radio when it's powered on.

**These small dishes have 80 - 100 watts of ERP at 5.8 Ghz!  
The Mikrotik Basebox 2 has 30 dBm of power output.  
When fed to a Mikrotik 30dBi gain dish, that's 1 KW of ERP. Use caution!**

All this information and much, much more is available at the AREDN web site: [arednmesh.org](http://arednmesh.org)